

## Introduction

The J6 is a NovaStar's high-performance seamless switcher that integrates video processing, screen mosaic, transition effects and multi-screen display capabilities. The J6 offers powerful video signal receiving and processing abilities and supports up to 8 inputs with the resolution up to 4K×2K@30Hz and 6 layers. In addition, this product supports two system modes: Splicer and Switcher. When it is in Splicer mode, a maximum of 4 DVI output connectors can be used together for output, which can realize an up to 8KK loading capacity of each J6 unit. When it is in Switcher mode, a maximum of 2 DVI output connectors can be used together for output, which can realize an up to 4KK loading capacity of each J6 unit.

Based on a powerful FPGA platform, the J6 supports input and output EDID management and color adjustment, seamless transition on a variety of input sources, as well as fade and other transition effects, bringing you a more flexible and rich visual experience.

What's more, the J6 is equipped with NovaStar's smart control software V-Can and C1 event controller, allowing for a rich screen mosaic effect via V-Can, C1 or front panel operations. With excellent image quality, ultra-large loading capacity and flexible operation modes, the J6 can be widely used in conference reports, exhibition centers, stage control and other application scenarios.

## Features

- Industry-standard input connectors
  - DVI connector: 1920×1080@60Hz input
  - HDMI 1.3 connector: 1920×1080@60Hz input
  - 3G-SDI connector: 1920×1080@60Hz input
  - DP 1.1 connector: 4K×2K@30Hz input
  - HDMI 1.4 connector: 4K×2K@30Hz input
- 4 groups (2 connectors in each group) of DVI output connectors of a single J6 unit for mosaic output
 

Each group includes a main connector and a backup connector. A maximum of 4 connectors can be used for mosaic output. The mosaic layout can be 4×1, 1×4 or 2×2. The maximum loading capacity can reach 9,200,000 pixels and the maximum mosaic width can be up to 15360 pixels.
- Dual system modes
 

Supports both Splicer and Switcher modes, which can meet different application requirements.
- Multiple layer display
 

Supports up to 6x 4K×2K layers that can be positioned freely and cross connector output.

Supports layer border settings.
- HDMI connector dedicated for output monitoring
  - Supports monitoring of a single input source, PVW or PGM.
- Supports mixed monitoring of all input sources, PVW and PGM.
- Supports displaying of input resolution and refresh rate.
- Display control function
 

Makes the screen fade to black or freeze the screen by simply clicking one button.
- EDID management
 

Supports input resolution management on DVI, HDMI and DP connectors.
- Transition effects
 

In Splicer mode, the device supports the setting of transition effect for source and preset switching.

In Switcher mode, the device supports the setting of Take effect and effect duration.
- BKG capturing
 

Supports the capturing of input source and PGM, and the captured image can be used as BKG.
- BKG image and pure color BKG
 

Supports both image BKG and pure color BKG. Up to 6 BKG images are supported.
- Adjustable input color, layer color and output color
- Preset management
 

Up to 10 presets are supported and the preset can be loaded simply by clicking one button.

- Layer layout management  
The device is built-in with 7 layer layouts. You can load one of the layer layouts to quickly lay out the layers.
- Multiple operation modes  
The device can be controlled via its front panel, the smart control software V-Can or C1 event controller.
- Multiple J6 units controlled by one C1 unit

- You can perform operations, such as FTB, freeze or Take operation, to multiple J6 units on the C1.
- AUX  
In Switcher mode, the device supports the AUX function.
- Intuitive LCD screen and clear button indicators on front panel, simplifying system control operations

## Front Panel



| No. | Button               | Description  |
|-----|----------------------|--|
| 1   | ON/OFF button        | <ul style="list-style-type: none"> <li>• Press ON to power on the device.</li> <li>• Press OFF to power off the device.</li> </ul>   |
| 2   | Layer buttons        | <p>Open or close a layer, and show the layer status.</p> <p>Status LEDs:</p> <ul style="list-style-type: none"> <li>• On: The layer is open, and the input source is accessed normally.</li> <li>• Dim: The layer is open, but the input source is abnormal.</li> <li>• Off: The layer is not opened.</li> <li>• Flashing: The layer is being edited.</li> </ul> <p>Hold down the layer button for 2s or longer to close the opened layer.</p>                                 |
| 3   | Input source buttons | <p>Switch the layer input source and show the input source status.</p> <p>Status LEDs:</p> <ul style="list-style-type: none"> <li>• On: The input source is accessed and in normal use.</li> <li>• Dim: The input source is accessed but not in use.</li> <li>• Off: The input source is not accessed or the source signal is abnormal.</li> </ul>   |
| 4   | LCD screen           | Display the device menus, submenus and messages.   |
| 5   | Knob                 | <ul style="list-style-type: none"> <li>• On the home screen, press the knob to enter the operation menu screen.</li> <li>• On the operation menu screen, rotate the knob to select a menu item, and press the knob to confirm the selection or enter the submenu.</li> <li>• When a menu item with parameters is selected, rotate the knob to adjust the parameters. Please note that after adjustment, you need to press the knob again to confirm the adjustment.</li> </ul> |

| No. | Button           | Description  |
|-----|------------------|--|
| 6   | Freeze button    | Freeze or unfreeze the output image.<br>Status LEDs:<br><ul style="list-style-type: none"> <li>On: The freeze function is enabled.</li> <li>Off: The freeze function is disabled.</li> </ul>   |
| 7   | ESC button       | Press the button to exit the current menu or cancel the operation.   |
| 8   | Function buttons | <ul style="list-style-type: none"> <li>PRESET: Enter the preset menu.</li> <li>BKG: Enable or disable the BKG function.</li> <li>FTB/TEST: Press the button to make the screen fade to black and press the button again to exit the FTB mode. Hold down the button for 2s or longer to enter the test pattern menu.</li> <li>FN/TAKE: The function of this button varies in different system modes (Splicer and Switcher). <ul style="list-style-type: none"> <li>In Splicer mode, press the button to enter the menu of the function that has been customized for Fn button. Hold down the button to enter the FN settings menu.</li> <li>In Switcher mode, press the button to send PVW to PGM.</li> </ul> </li> </ul> |

## Rear Panel

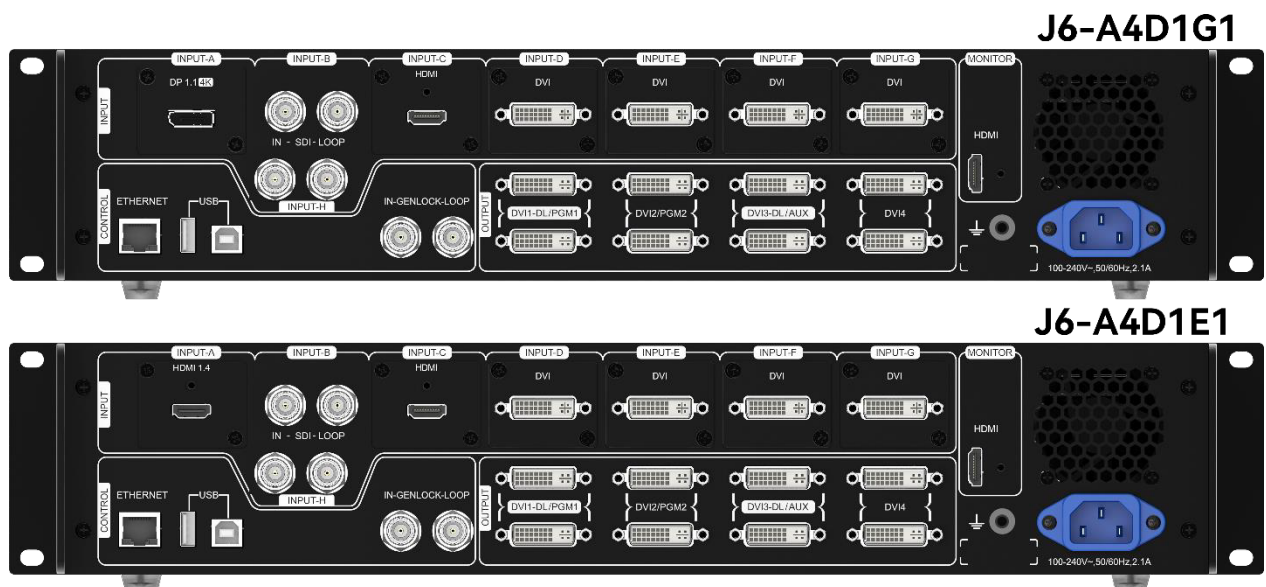

### Notes:

- The picture shown is for illustration purpose only. Actual product may vary due to product enhancement.
- The J6 provides two default configurations that differ in Input-F and Input-G connectors on the rear panel.
- DP 1.1 and HDMI 1.4 connectors support at most 2 layers. Other connectors support at most 6 layers.

| Input   |           |   |
|---------|-----------|---|
| No.     | Connector | Description   |
| INPUT-A | DP 1.1    | Input resolution up to 3840×2160@30Hz and custom EDID supported<br>HDCP 1.3 compliant<br><br>Interchangeable with HDMI 1.4 input card (Input resolution up to 3840×2160@30Hz and custom EDID supported, HDCP 1.4 compliant) |

|                               |                  |  |
|-------------------------------|------------------|--|
|                               |                  | Does not support interlaced signal inputs.   |
| INPUT-B                       | 3G-SDI           | Input resolution up to 1920×1080@60Hz<br>Loop through function<br>Interlaced signal processing supported<br>Does not support input resolution and bit depth settings.  |
| INPUT-C                       | HDMI 1.3         | Input resolution up to 1920×1080@60Hz and custom EDID supported<br>HDCP 1.4 compliant<br>Interlaced signal processing supported<br>Interchangeable with DVI or 3G-SDI input card   |
| INPUT-D                       | DVI              | Input resolution up to 1920×1080@60Hz, other VESA standard resolutions and custom EDID supported<br>HDCP 1.4 compliant<br>Interchangeable with HDMI 1.3 or 3G-SDI input card<br>Does not support interlaced signal inputs.   |
| INPUT-E                       |                  |  |
| INPUT-F                       | -                | The J6 has two default versions.   |
| INPUT-G                       | DP 1.1 / DVI     | <ul style="list-style-type: none"> <li>Version I: INPUT-G is DP 1.1 input card that supports up to 3840×2160@30Hz video source input and custom EDID. When it is changed to HDMI 1.4 input card, the INPUT-F is unavailable.</li> <li>Version II: INPUT-F and INPUT-G are DVI input cards that support up to 1920×1080@60Hz and other VESA-standard compliant video source inputs and custom EDID. The two connectors both can be changed to HDMI 1.3 or 3G-SDI input card.</li> </ul> |
| INPUT-H                       | 3G-SDI           | Input resolution up to 1920×1080@60Hz<br>Loop through function<br>Interlaced signal processing supported   |
| <b>Output</b>                 |                  |  |
| <b>No.</b>                    | <b>Connector</b> | <b>Description</b>   |
| DVI                           | 8                | 4 groups (2 connectors in each group) of DVI output connectors can be used for mosaic output.<br><br>Each group includes a main connector and a backup connector.<br><br>The J6 supports dual-link DVI output mode. When the output is set to dual-link mode, DVI 1 and DVI 3 are used as output connectors, while DVI 2 and DVI 4 are unavailable.<br><br>In Splicer mode, DVI 3 can be used for AUX.   |
| MONITOR                       | 1                | An HDMI connector dedicated for monitoring all input sources, a single input source, PVW and PGM.  |
| <b>Control</b>                |                  |  |
| ETHERNET                      | 1                | Communicate with the control PC or connect to the network.   |
| USB (Type-B)                  | 1                | Connect to the control PC for device control.  |
| USB (Type-A)                  | 1                | A reserved connector.  |
| <b>Overall Specifications</b> |                  |  |
| Power                         | 1                | AC100-240V~50/60Hz   |

# Applications

The J6 supports dual system modes: Splicer and Switcher. The connections for two modes are shown in [Figure 1](#) and [Figure 2](#).

Figure 1 Connections for Splicer mode

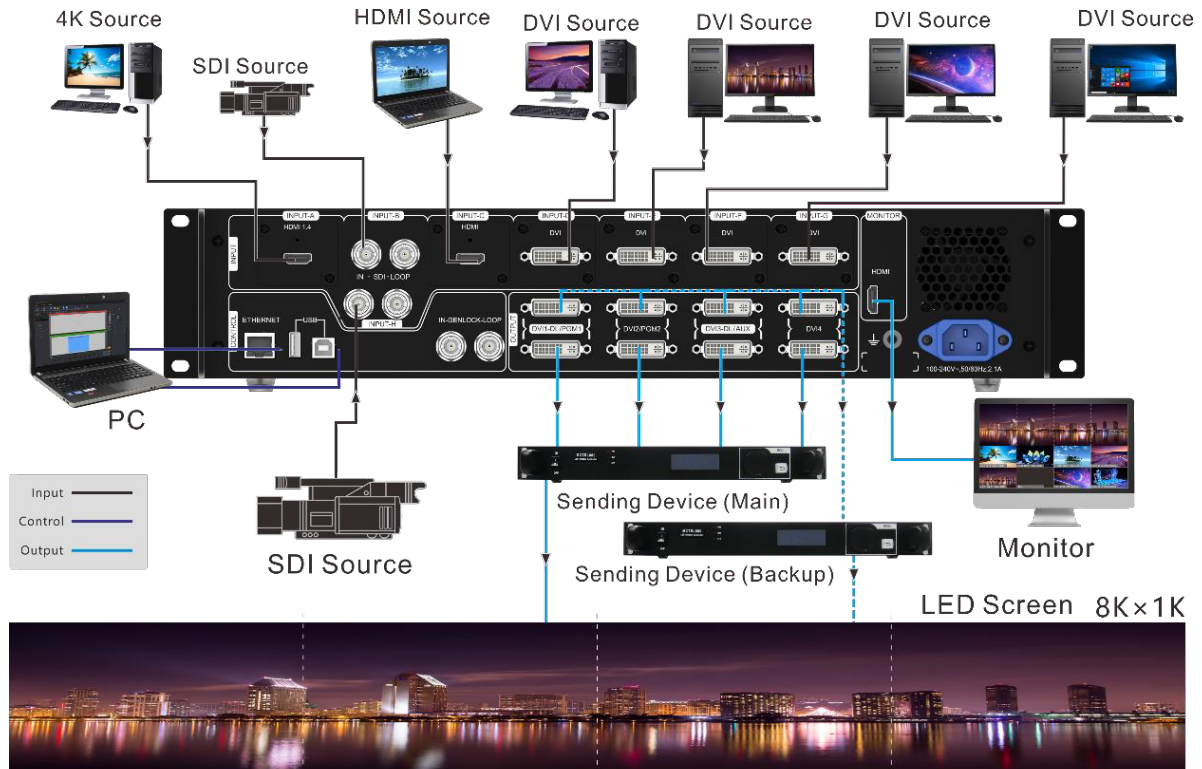
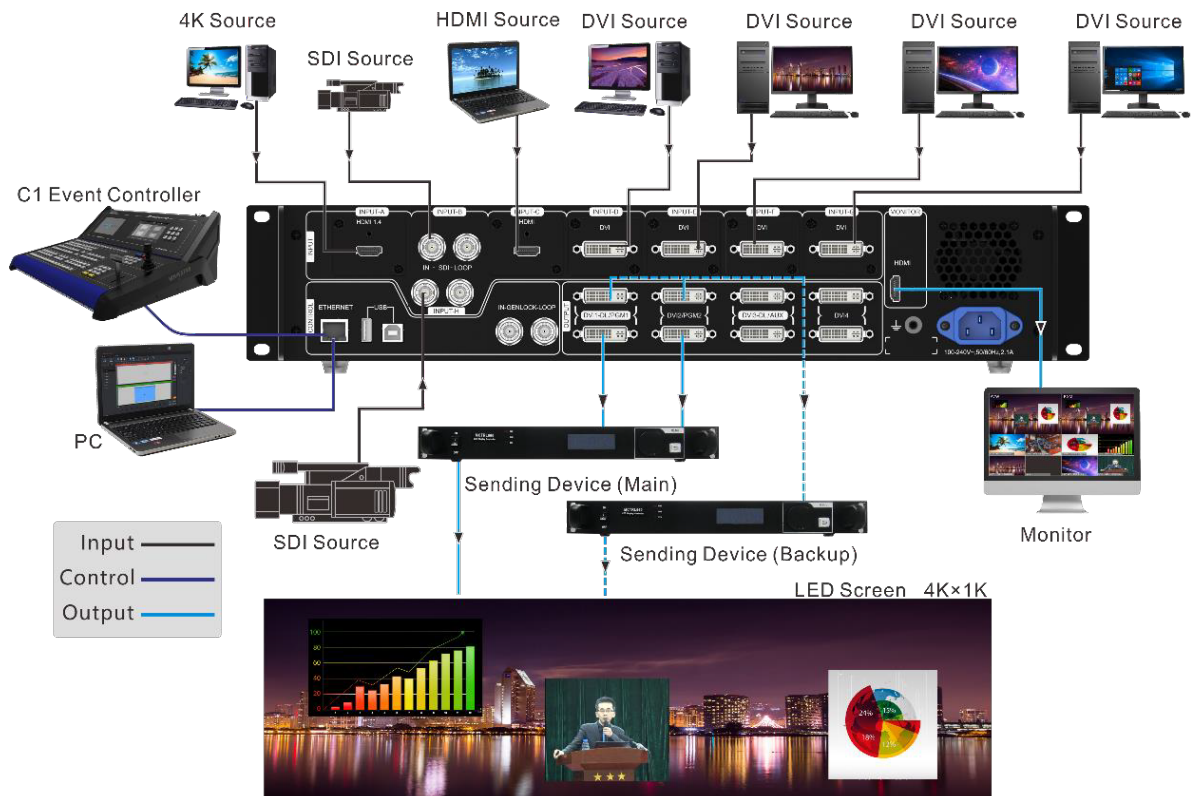
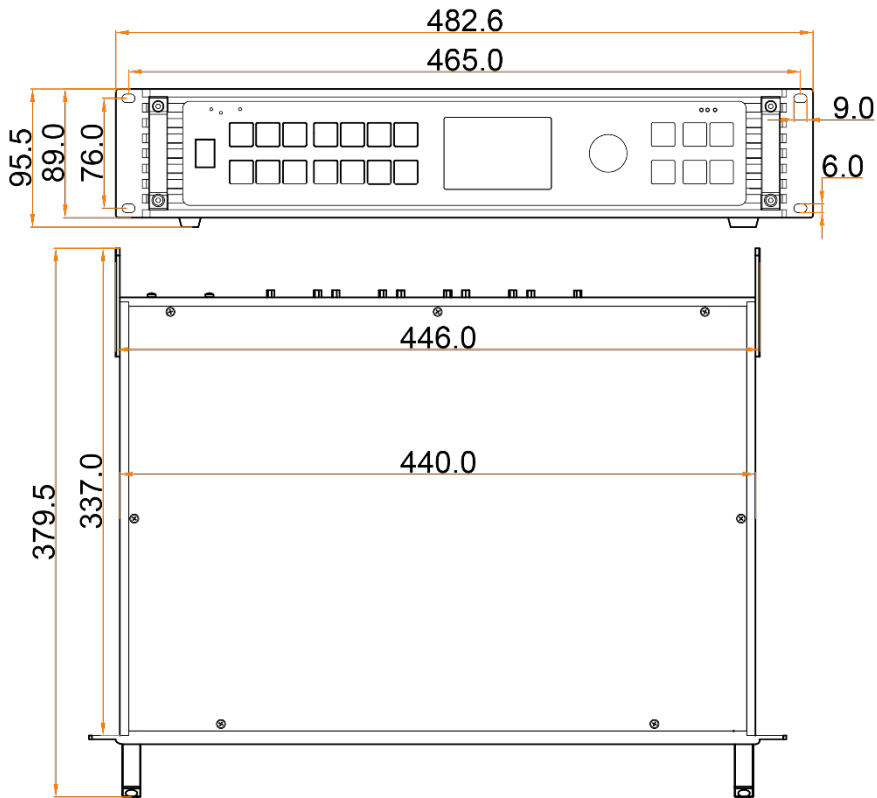

Figure 2 Connections for Switcher mode



# Dimensions

## J6 Dimensions



Tolerance:  $\pm 0.3$  Unit: mm

## Flight Case Dimensions

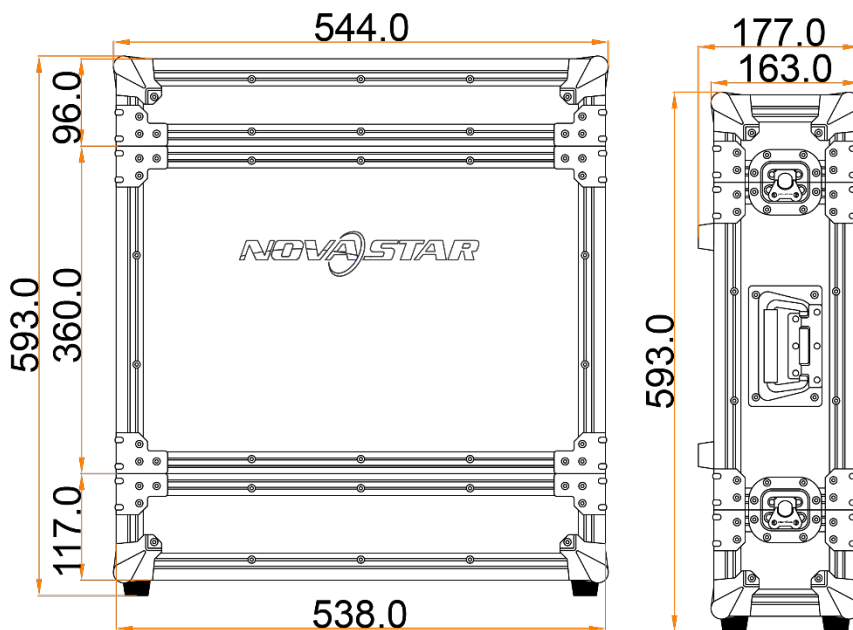

Tolerance:  $\pm 0.3$  Unit: mm

### Note :

For detailed dimension drawings of the flight case, please contact NovaStar's customer service staff.

# Specifications

| Connector performance  |  | Common resolutions         |  |
|--|--|----------------------------|--|
| <ul style="list-style-type: none"> <li>• DVI</li> <li>• HDMI 1.3</li> </ul>    | 800×600@50/60/75/85Hz                        | 1366×768@50/60Hz           |  |
|  | 1024×768@48/50/60/75/85Hz                    | 1366×800@50/60Hz           |  |
|  | 1152×864@75Hz                                | 1400×1050@48/50/60/75Hz    |  |
|  | 1280×720@48/50/60Hz                          | 1440×900@60/75/85Hz        |  |
|  | 1280×768@48/50/60/75Hz                       | 1600×900@48/50/60Hz        |  |
|  | 1280×800@50/60Hz                             | 1600×1200@48/50/60Hz       |  |
|  | 1280×960@50/60/85Hz                          | 1680×1050@60Hz             |  |
|  | 1280×1024@48/50/60/75/85Hz                   | 1792×1280@60Hz             |  |
|  | 1360×768@60Hz                                | 1920×1080@30/48/50/60Hz    |  |
|  | 1364×1024@48/50/85Hz                         | 1920×1200@50/60Hz          |  |
| <ul style="list-style-type: none"> <li>• DP 1.1</li> <li>• HDMI 1.4</li> </ul> | 800×600@50/60/75/85Hz                        | 1680×1050@60Hz             |  |
|  | 1024×768@48/50/60/75/85Hz                    | 1792×1280@60Hz             |  |
|  | 1152×864@75Hz                                | 1920×1080@30/48/50/60Hz    |  |
|  | 1280×720@48/50/60Hz                          | 1920×1200@50/60Hz          |  |
|  | 1280×768@48/50/60/75Hz                       | 2048×1080@30/48/50/60Hz    |  |
|  | 1280×800@50/60Hz                             | 2048×1152@30Hz             |  |
|  | 1280×960@50/60/85Hz                          | 2304×1152@60Hz             |  |
|  | 1280×1024@48/50/60/75/85Hz                   | 2048×1152@60Hz             |  |
|  | 1360×768@60Hz                                | 2560×1080@50/60Hz          |  |
|  | 1364×1024@48/50/85Hz                         | 2560×1400@50/60Hz          |  |
|  | 1400×1050@48/50/60/75Hz                      | 2560×1600@50/60Hz          |  |
|  | 1440×900@60/75/85Hz                          | 3840×1080@30/50/60Hz       |  |
|  | 1600×900@48/50/60Hz                          | 3840×2160@30Hz             |  |
|  | 1600×1200@48/50/60Hz                         |                            |  |
| 3G-SDI   | 720×486i@59.94Hz                             |                            |  |
|  | 720×576i@50Hz                                |                            |  |
|  | 1280×720@23.98/24/25/29.97/30/50/59.94/60Hz  |                            |  |
|  | 1920×1080i@50/59.94/60Hz                     |                            |  |
|  | 1920×1080@23.98/24/25/29.97/30/50/59.94/60Hz |                            |  |
| Overall Specifications   |  |                            |  |
| Electrical specifications  | Power connector                              | 100-240V~, 50/60Hz, 2.1A   |  |
|  | Power consumption                            | 50 W                       |  |
| Operating environment  | Operating temperature                        | -20°C to +70°C             |  |
|  | Operating humidity                           | 20% to 90%, non-condensing |  |
|  | Storage humidity                             | 10% to 95%, non-condensing |  |
| Physical specifications  | Dimensions                                   | 482.6mm × 379.5mm × 95.5mm |  |

|                                    |              |  |
|------------------------------------|--------------|--|
|                                    | Net weight   | 5.3 kg   |
|                                    | Gross weight | 15 kg  |
| Packing information                | Accessory    | 1x Power cord, 1x Ethernet cable, 2x DVI cables,<br>1x USB cable, 1x HDMI cable, 1x HDMI to DVI cable,<br>1x mini DP to DP cable<br>1x Flight case, 1x User Manual |
|                                    | Flight case  | 593mm × 544mm × 177mm  |
| Noise Level (typical at 25°C/77°F) |              | 50 dB(A)   |

## Video Source Features

| Input Connector    | Color Depth  |             | Max. Input Resolution |
|--------------------|--|-------------|-----------------------|
| DP 1.1<br>HDMI 1.4 | 8 bit  | RGB 4:4:4   | 3840×1080@60Hz        |
|                    |  | YCbCr 4:4:4 |                       |
|                    |  | YcbCr 4:2:2 |                       |
|                    | 10 bit   | -           | Unsupported           |
| 12 bit             | -  |             |                       |
| HDMI 1.3           | 8 bit  | RGB 4:4:4   | 1920×1080@60Hz        |
|                    |  | YCbCr 4:4:4 | 1920×1080@60Hz        |
|                    |  | YCbCr 4:2:2 |                       |
|                    | 10 bit   | -           | Unsupported           |
|                    | 12 bit   | -           |                       |
| DVI                | 8 bit  | RGB 4:4:4   | 1920×1080@60Hz        |
| 3G-SDI             | Maximum input resolution: 1920×1080@60Hz<br>Does not support input resolution and bit depth settings.<br>Supports ST-424 (3G) and ST-292 (HD) input signals. |             |                       |

## Certifications

RCM, UL/CUL, IC, CB, RoHS, FCC, LVD, EMC

**If the product does not have the relevant certifications required by the countries or regions where it is to be sold, please contact NovaStar to confirm or address the problem. Otherwise, the customer shall be responsible for the legal risks caused or NovaStar has the right to claim compensation.**

## FCC Caution

Any changes or modifications not expressly approved by the party responsible for compliance could void the user's authority to operate the equipment.

This device complies with part 15 of the FCC Rules. Operation is subject to the following two conditions: (1) This device may not cause harmful interference, and (2) this device must accept any interference received, including interference that may cause undesired operation.

Note: This equipment has been tested and found to comply with the limits for a Class A digital device, pursuant to part 15 of the FCC Rules. These limits are designed to provide reasonable protection against harmful interference when the equipment is operated in a commercial environment. This equipment generates, uses, and can radiate radio frequency energy and, if not installed and used in accordance with the instruction manual, may cause harmful interference to radio communications. Operation of this equipment in a residential area is likely to cause harmful interference in which case the user will be required to correct the interference at his own expense.

Features